

NOTICE DE MONTAGE TABOURET REF.6007034

DANNY GAS

The below assembly instructions can be used for the following code

564348-806780-806798

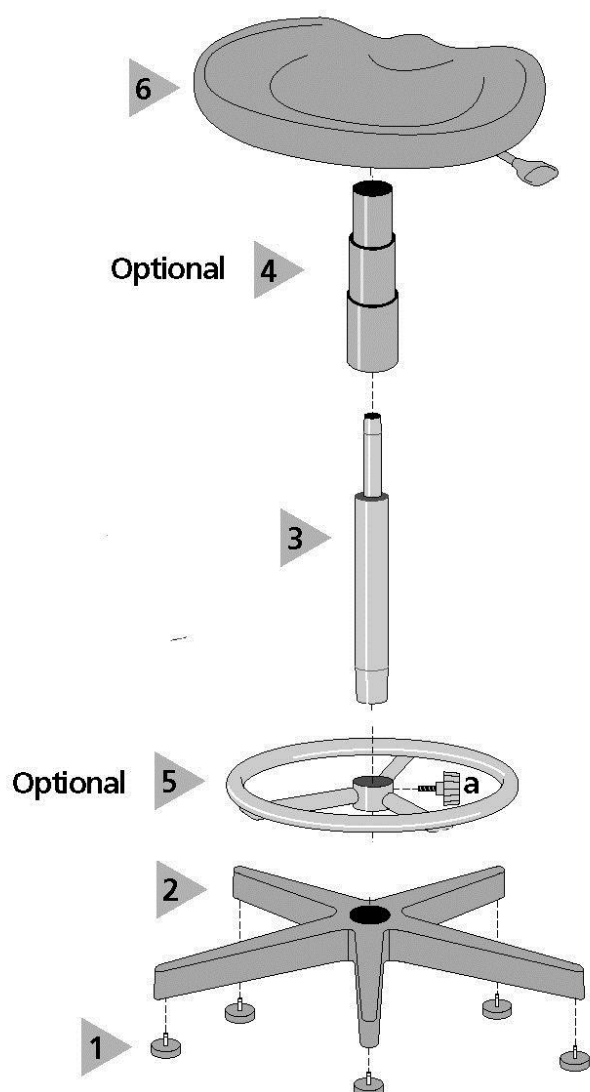

mod.

Lab Stool/Sgabello Danny Gas

ENGLISH

- 1,2 Insert the feet into the base.
- 3 Insert the gas lift in the central hole in the base.
- 4 Place the gas lift cover over the gas lift. (optional)
- 5 Place the foot-ring on to the gas lift and lock it using knob **a**. (optional)
- 6 Place the seat on the gas lift and exert a pressure downward.

FRANÇAIS

- 1,2 Introduire les petits pieds dans la base.
- 3 Introduire la pompe à gaz dans la cavité centrale de la base.
- 4 Insérez le soufflet télescopique sur la pompe à gaz. (optional)
- 5 Appuyer l'anneau repose-pied sur la pompe à gaz et fixer avec la poignée **a**. (optional)
- 6 Appuyer le siège sur la pompe à gaz et exercer une pression vers le bas.

DEUTSCH

- 1,2 Die Fußgummis in die Beinenden stecken.
- 3 Die feste Gaspumpe in das Loch in der Mitte des Sockels stecken.
- 4 Den Teleskop-faltenbalg über die Pumpe stülpen. (optional)
- 5 Den Stützring für die Füße auf die feste Gaspumpe legen und sie mit dem Schwungrad **a** festdrehen. (optional)
- 6 Die Sitz auf der Gaspumpe anbringen.

ESPAÑOL

- 1,2 Introducir los pies en la base.
- 3 Introducir la pompa de gas en el agujero central de la base.
- 4 Montar el fuelle telescópico sobre la pompa de gas. (optional)
- 5 Apoyar el reposapiés anular en la pompa de gas y bloquearlo con la rueda **a**. (optional)
- 6 Apoyar el asiento sobre la pompa de gas.

ITALIANO

- 1,2 Infilare i piedini nella base.
- 3 Infilare la pompa a gas nel foro centrale della base.
- 4 Infilare il soffietto telescopico sulla pompa a gas. (optional)
- 5 Appoggiare la raggiera poggiapiedi sulla pompa a gas e bloccarla con il volantino **a**. (optional)
- 6 Appoggiare il sedile sulla pompa a gas.

NEDERLANDS

- 1,2 Plaats de glijdoppen in het voetkruis.
- 3 Plaats de gaslifter in de bovenkant van het voetkruis.
- 4 Schuif de telescoop over de gaslifter.
- 5 Plaats de voetring op de gaslifter en zet deze vast met de schroefknop.
- 6 Druk de zitting op de gaslifter.

IMPORTANT INFORMATION REGARDING OUR SEATING PRODUCTS:

Do not use the chair inappropriately.

Use this product only for seating one person at a time.

Do not stand on the chair.

Do not use chair unless all bolts, screws and knobs are tight.

At least every 2 months, check all bolts, screws and knobs to be sure they are tight.

If parts are missing, broken or worn, stop use of the product until repairs are made using factory authorized parts.

FAILURE TO FOLLOW THESE WARNINGS CAN RESULT IN SERIOUS INJURY!

General information:

The seating product you have has been designed for normal use, which is in typical office environment for 8 hours per day, 5 days per week.

The castors furnished with the seating product are intended for use on soft floor materials, such as carpet.

REMEMBER:

AT LEAST EVERY 2 MONTHS, CHECK ALL KNOBS, BOLTS AND SCREWS TO MAKE SURE THEY ARE TIGHT AND SECURE.